

N-Channel MOSFET

Features

- $R_{DS(on)}$ (Max 1.5 Ω)@ $V_{GS}=10V$
- Gate Charge (Typical 18.5nC)
- Improved dv/dt Capability
- High ruggedness
- 100% Avalanche Tested

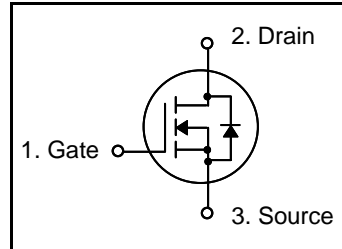

$$BV_{DSS} = 500V$$

$$R_{DS(ON)} = 1.5 \text{ ohm}$$

$$I_D = 5.3A$$

General Description

This N-channel enhancement mode field-effect power transistor using DI semiconductor's advanced planar stripe, DMOS technology intended for off-line switch mode power supply.

Also, especially designed to minimize $r_{ds(on)}$ and high rugged avalanche characteristics. The TO-220 pkg is well suited for half bridge and full bridge resonant topology like a electronic ballast.

TO-220

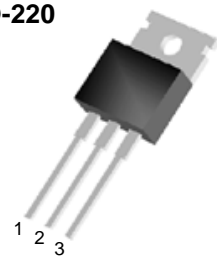

Absolute Maximum Ratings

Symbol	Parameter	Value	Units
V_{DSS}	Drain to Source Voltage	500	V
I_D	Continuous Drain Current(@ $T_C = 25^\circ C$)	5.3	A
	Continuous Drain Current(@ $T_C = 100^\circ C$)	3.4	A
I_{DM}	Drain Current Pulsed (Note 1)	21.2	A
V_{GS}	Gate to Source Voltage	± 30	V
E_{AS}	Single Pulsed Avalanche Energy (Note 2)	390	mJ
E_{AR}	Repetitive Avalanche Energy (Note 1)	9.84	mJ
dv/dt	Peak Diode Recovery dv/dt (Note 3)	4.5	V/ns
P_D	Total Power Dissipation(@ $T_C = 25^\circ C$)	98.4	W
	Derating Factor above 25 $^\circ C$	0.78	W/ $^\circ C$
T_{STG}, T_J	Operating Junction Temperature & Storage Temperature	- 55 ~ 150	$^\circ C$
T_L	Maximum Lead Temperature for soldering purpose, 1/8 from Case for 5 seconds.	300	$^\circ C$

Thermal Characteristics

Symbol	Parameter	Value			Units
		Min.	Typ.	Max.	
$R_{\theta JC}$	Thermal Resistance, Junction-to-Case	-	-	1.27	$^\circ C/W$
$R_{\theta CS}$	Thermal Resistance, Case to Sink	-	0.5	-	$^\circ C/W$
$R_{\theta JA}$	Thermal Resistance, Junction-to-Ambient	-	-	62	$^\circ C/W$

DFP830

Electrical Characteristics (T_C = 25 °C unless otherwise noted)

Symbol	Parameter	Test Conditions	Min	Typ	Max	Units
Off Characteristics						
BV _{DSS}	Drain-Source Breakdown Voltage	V _{GS} = 0V, I _D = 250uA	500	-	-	V
$\frac{\Delta BV_{DSS}}{\Delta T_J}$	Breakdown Voltage Temperature coefficient	I _D = 250uA, referenced to 25 °C	-	0.47	-	V/°C
I _{DSS}	Drain-Source Leakage Current	V _{DS} = 500V, V _{GS} = 0V	-	-	1	uA
		V _{DS} = 400V, T _C = 125 °C	-	-	10	uA
I _{GSS}	Gate-Source Leakage, Forward	V _{GS} = 30V, V _{DS} = 0V	-	-	100	nA
	Gate-source Leakage, Reverse	V _{GS} = -30V, V _{DS} = 0V	-	-	-100	nA
On Characteristics						
V _{GS(th)}	Gate Threshold Voltage	V _{DS} = V _{GS} , I _D = 250uA	2.0	-	4.0	V
R _{DS(ON)}	Static Drain-Source On-state Resistance	V _{GS} = 10V, I _D = 2.65A	-	1.2	1.5	Ω
Dynamic Characteristics						
C _{iss}	Input Capacitance	V _{GS} = 0V, V _{DS} = 25V, f = 1MHz	-	608	-	pF
C _{oss}	Output Capacitance		-	75	-	
C _{rss}	Reverse Transfer Capacitance		-	25	-	
Dynamic Characteristics						
t _{d(on)}	Turn-on Delay Time	V _{DD} = 250V, I _D = 5.3A, R _G = 25Ω * see fig. 13. (Note 4, 5)	-	16	42	ns
t _r	Rise Time		-	49	108	
t _{d(off)}	Turn-off Delay Time		-	60	130	
t _f	Fall Time		-	49	108	
Q _g	Total Gate Charge	V _{DS} = 400V, V _{GS} = 10V, I _D = 5.3A * see fig. 12. (Note 4, 5)	-	18.5	23	nC
Q _{gs}	Gate-Source Charge		-	4	-	
Q _{gd}	Gate-Drain Charge(Miller Charge)		-	8	-	

Source-Drain Diode Ratings and Characteristics

Symbol	Parameter	Test Conditions	Min.	Typ.	Max.	Unit.
I _S	Continuous Source Current	Integral Reverse p-n Junction Diode in the MOSFET	-	-	5.3	A
I _{SM}	Pulsed Source Current		-	-	21.2	
V _{SD}	Diode Forward Voltage	I _S = 5.3A, V _{GS} = 0V	-	-	1.5	V
t _{rr}	Reverse Recovery Time	I _S = 5.3A, V _{GS} = 0V, dI _F /dt = 100A/us	-	302	-	ns
Q _{rr}	Reverse Recovery Charge		-	1.8	-	uC

* NOTES

1. Repeatability rating : pulse width limited by junction temperature
2. L = 25mH, I_{AS} = 5.3A, V_{DD} = 50V, R_G = 50Ω, Starting T_J = 25°C
3. I_{SD} ≤ 5.3A, di/dt ≤ 300A/us, V_{DD} ≤ BV_{DSS}, Starting T_J = 25°C
4. Pulse Test : Pulse Width ≤ 300us, Duty Cycle ≤ 2%
5. Essentially independent of operating temperature.

Fig 1. On-State Characteristics

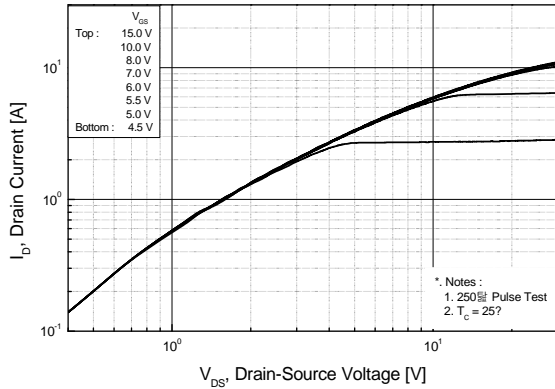

Fig 2. Transfer Characteristics

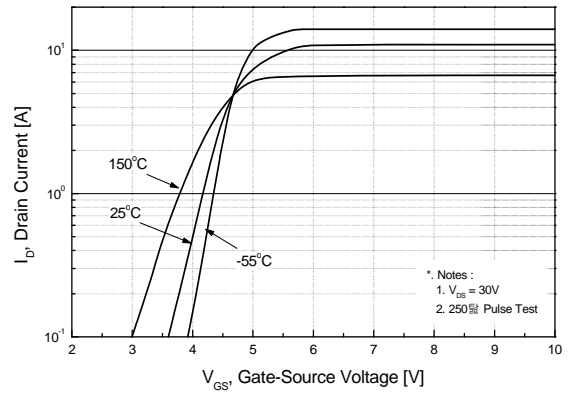

Fig 3. On Resistance Variation vs. Drain Current and Gate Voltage

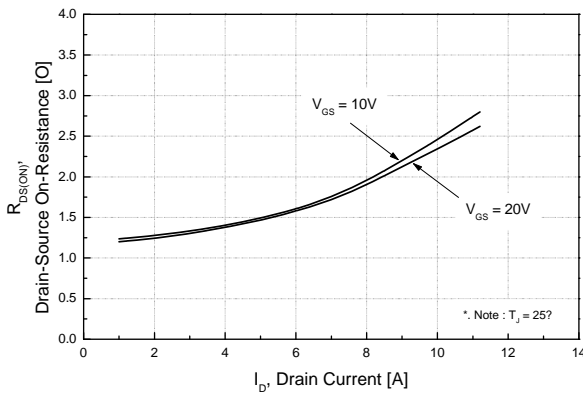

Fig 4. On State Current vs. Allowable Case Temperature

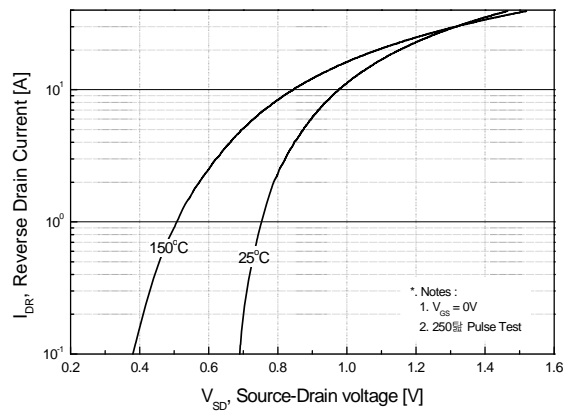

Fig 5. Capacitance Characteristics (Non-Repetitive)

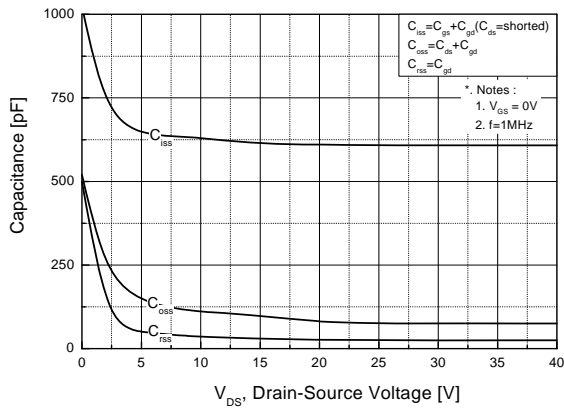

Fig 6. Gate Charge Characteristics

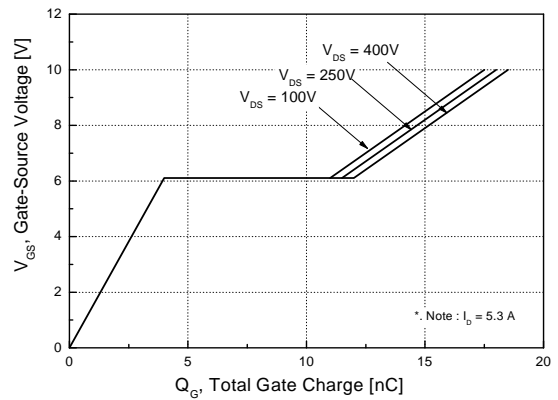

Fig 7. Breakdown Voltage Variation vs. Junction Temperature

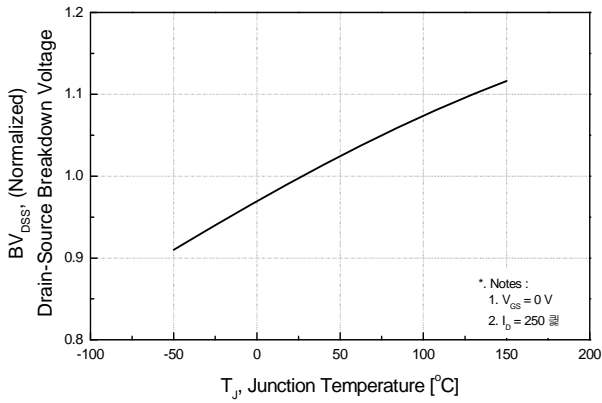

Fig 8. On-Resistance Variation vs. Junction Temperature

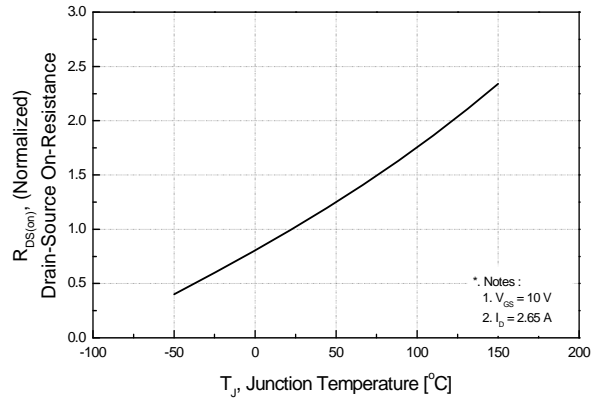

Fig 9. Maximum Safe Operating Area

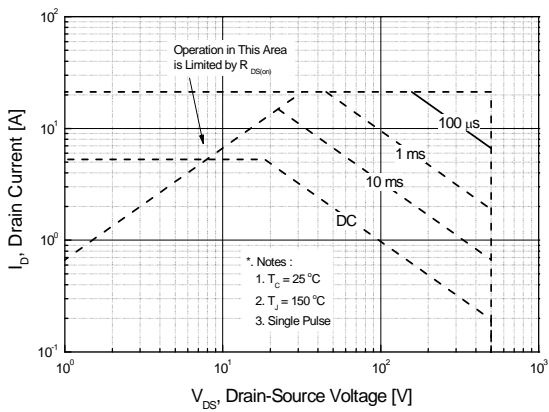

Fig 10. Maximum Drain Current vs. Case Temperature

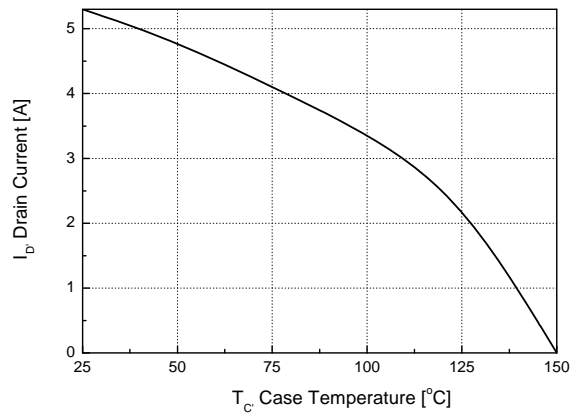

Fig 11. Transient Thermal Response Curve

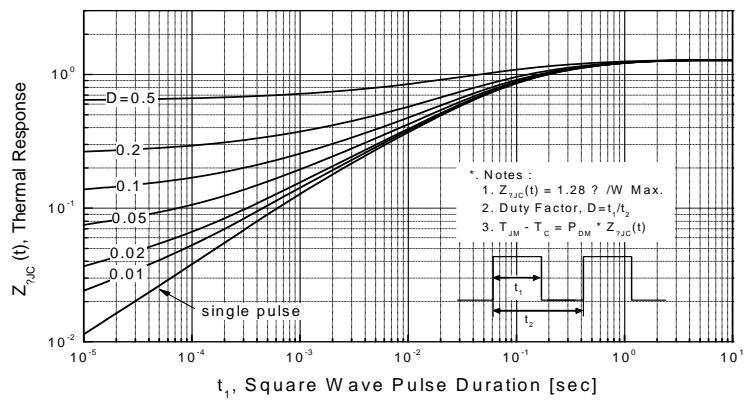

Fig. 12. Gate Charge Test Circuit & Waveforms

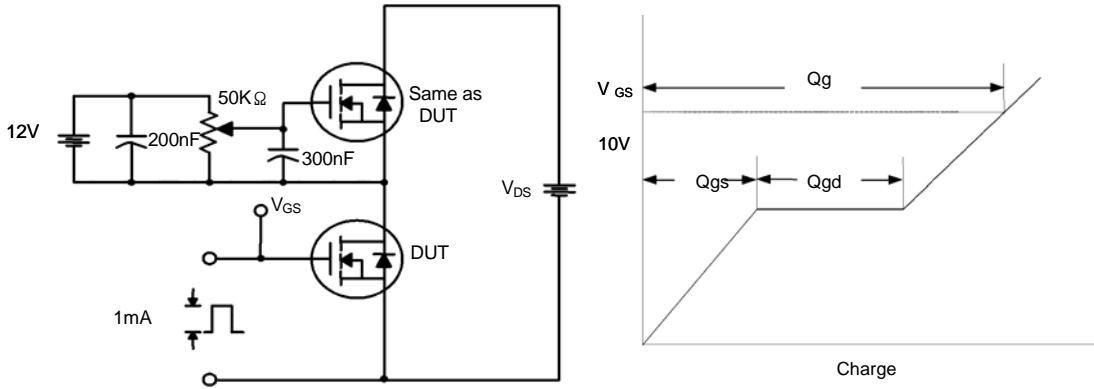

Fig. 13. Switching Time Test Circuit & Waveforms

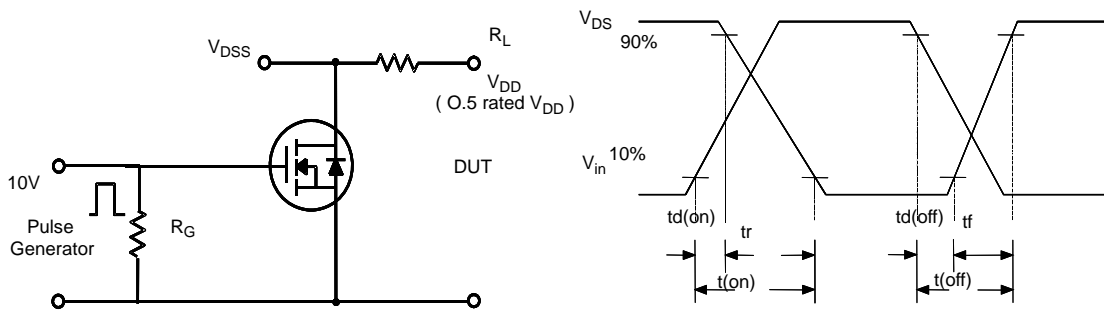
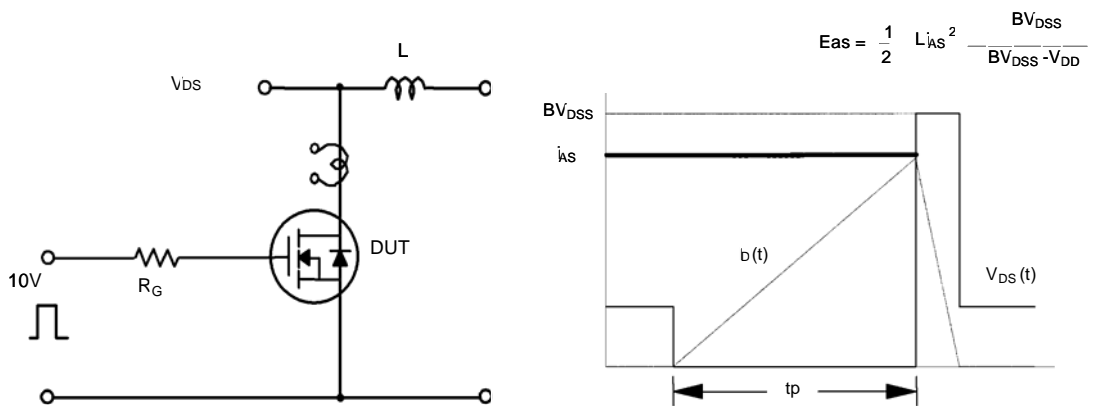
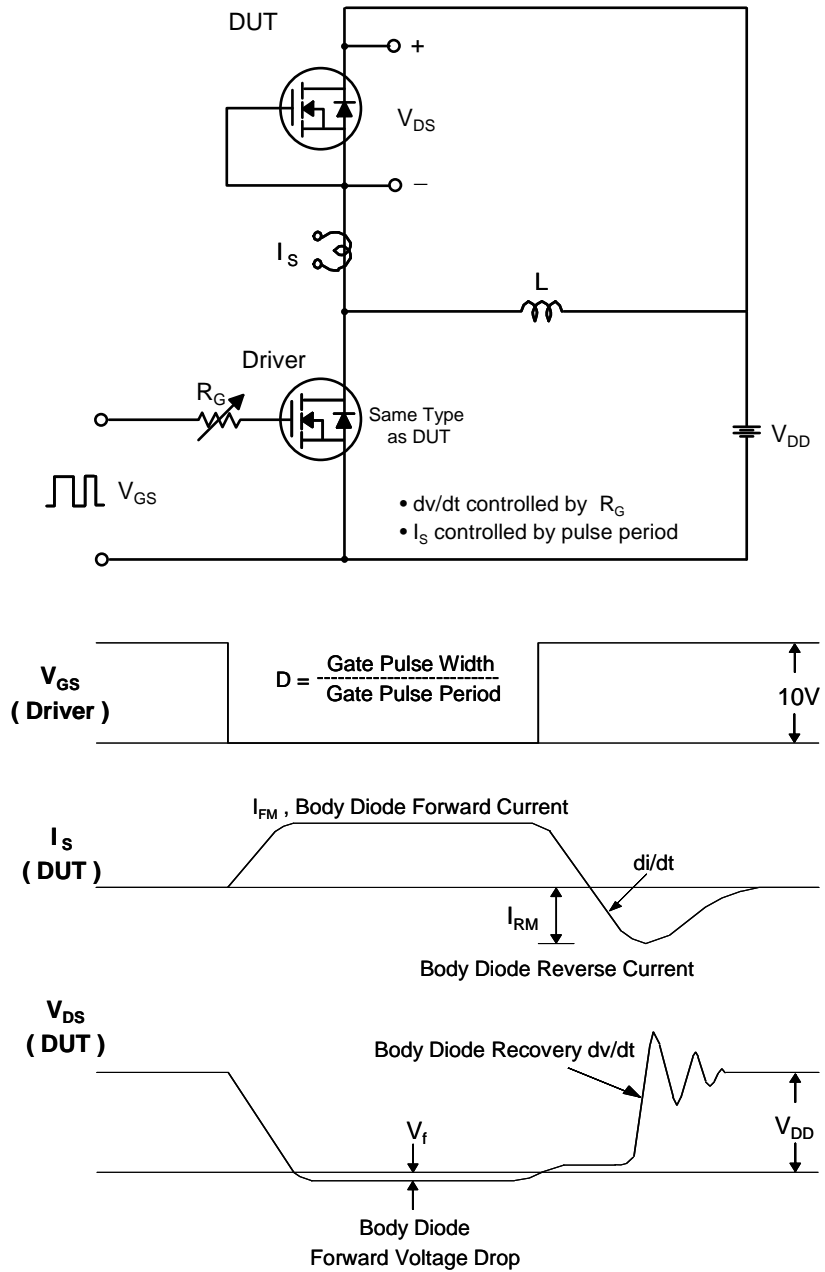

Fig. 14. Unclamped Inductive Switching Test Circuit & Waveforms



DFP830

Fig. 15. Peak Diode Recovery dv/dt Test Circuit & Waveforms



TO-220 Package Dimension

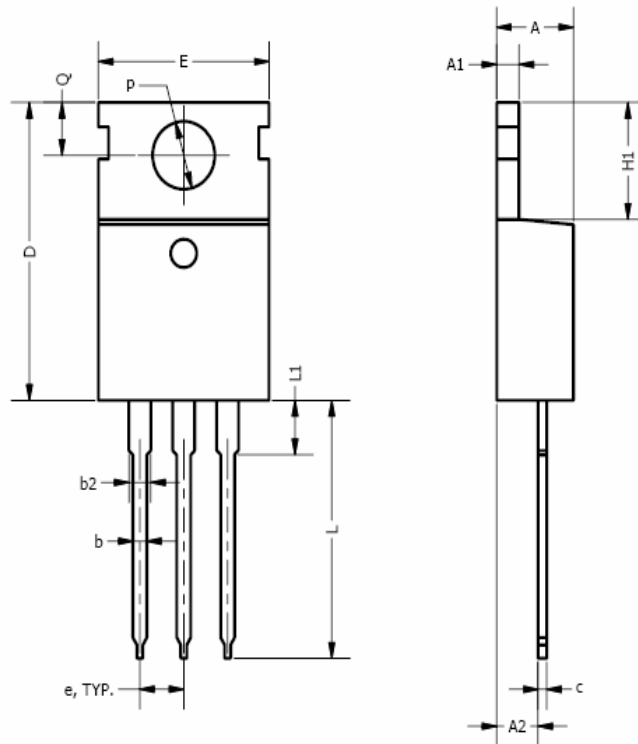

DIM	INCHES		MILLIMETERS	
	MIN	MAX	MIN	MAX
A	0.14	0.19	3.56	4.83
A1	0.02	0.055	0.51	1.4
A2	0.08	0.115	2.03	2.92
b	0.015	0.04	0.38	1.02
b2	0.045	0.07	1.14	1.78
c	0.014	0.024	0.36	0.61
D	0.56	0.65	14.22	16.51
e	0.096	0.104	2.44	2.64
E	0.38	0.42	9.65	10.67
H1	0.23	0.27	5.84	6.86
L	0.5	0.58	12.7	14.73
L1	-	0.25	-	6.35
∅P	0.139	0.161	3.53	4.09
Q	0.1	0.135	2.54	3.43